

# **MODEL GCS2000**

## **Portable Gas Cooling System**

---



---

### **GCS2000 TECHNOLOGY PROVIDING**

---

- **Pell tier cooler-controlled**
- **Temp controller 0 ~25℃**
- **User - friendly operation and set-up**
- **Internal pump (Option)**
- **Dehumidifier**
- **Dust filter**

## Performance Characteristics

### Gas Cooling System

Model : GCS2000

Temp set point range : 0 ~ 25 °C

Resolution : 1 °C

Oper Temp range : -20 °C to +60 °C

Pressure range : Atmospheric ± 10%

Warm-up time : 10 min

Sample flow rate : 6ℓ /min

Out Flow meter : 1 to 5ℓ /min

Sample pump : 6ℓ /min option

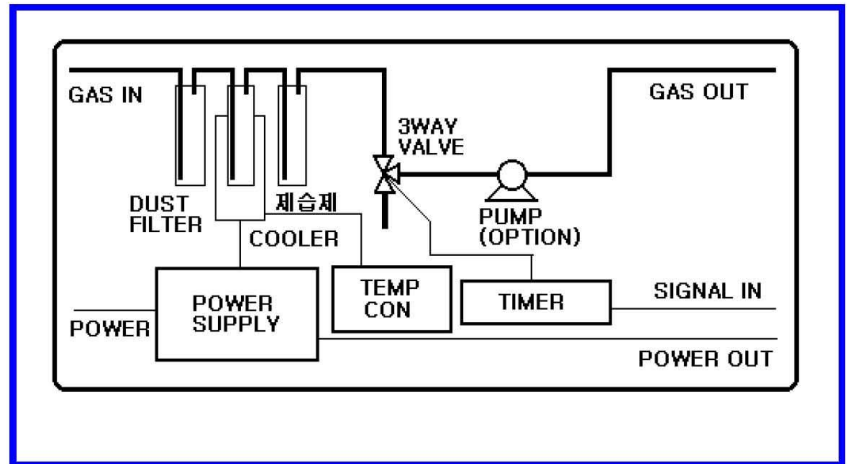

## Technical Specification

Electrical connections	220V Euro plug for power input
	6P connector for remote control
Output	DC 12V 10A
Gas connections	¼ " compression fitting panel entries
Installation	Portable aluminum case
Case material	Aluminum
Operating condition	0 to 40 °C ambient temperature
	0 to 95% relative humidity
Gas conditions	0 to 150 °C non condensing at system entry
Power	Nominal 220V/60 Hz
dimension	425 x 215 x 330
Weight	6Kg

W I T H U S

대전광역시 대덕구 대화동 289-1

산업용재유통단지 11동 112호

TEL : 042)6 7 0 - 7 8 4 0

FAX : 042)6 7 0 - 7 8 4 8